

并联机器人

选型手册

Parallel Robot Selection Manual

D5



• 型号和符号

D5	1100	P0	A1	E1	FXGX
机型	型号	负载	控制器类型	控制柜类型	视觉
D5	1100	P0: 标准	A1: ATOMCONTROL A2: KEBA CONTROL	E1: ATOM-01 E2: ATOM-02 E3: 定制	F0G0: 无视觉 FXGX: 有视觉

• Model and Symbol

D5	1100	P0	A1	E1	FXGX
Robot type	Type	Load Type	Control Type	Control Cabinet	Vision Type
D5	1100	P0: Stadnard	A1: ATOMCONTROL A2: KEBA CONTROL	E1: ATOM-01 E2: ATOM-02 E3: Custom	F0G0: Without vision FXGX: With vision

D5-1100-P3



高速度
高精度
高稳定性
高自由度
小巧、敏捷

High speed
High precision
High stability
More degrees
Small and Agile

型号 Type		D5-1100-P0-A2
轴数 Axes		3+2
最大负载 Payload		2kg
机器人本体 Manipulator	重量 Weight	90kg
	工作空间直径 Diameter	1100mm
重复定位精度 repeatability	位置 Position	0.05mm
	旋转 Rotation	0.1°
旋转范围 Rotation range		±360°
俯仰范围 Vertical rotation range		±90°
允许负载最大旋转惯量 (水平旋转) Allowable maximum moment of inertia		$31 \times 10^{-4} \text{kg} \cdot \text{m}^2$
主动臂角度范围 Angle range of actuated arm	上摆 Up	36.5°
	下摆 Down	70.5°
输入电源 Power supply		三相 Three-phase 380VAC -10%~+10%, 49~61HZ
电源容量 Power capacity		3KVA
额定功率 Rated Power		1.3kw
保存温度 Storage temperature		-10°C~70°C
工作环境 Work environment		-10°C~50°C, RH≤80%
防护等级 Protection		IP55

- ◆ 具备3+2自由度，轻松满足复杂摆放场景。
With 3+2-DOF movement in three-dimensional space, robot can be used for more complicated handling operations
- ◆ 标准循环时间小于0.5s,满足追求最高速度和最小体积需求
The standard cycle time is less than 0.5s, meeting your pursuit for the maximum speed and the minimum volume.
- ◆ 特殊旋转轴铰链设计，轻松应对高强度高频次重复运动需求
Advanced design of Hooke joint in the rotational axis, enables the robot to easily cope with the high-intensity repetitive operation.
- ◆ 非常适于狭小空间内作业、3C制造等行业的高速高精生产作业，主要用于小型工件的装配、搬运、检测等
The robot is ideal for narrow space operations, as well as high-speed and high-precision in 3C field. Widely used in assembly, handling and testing of small work pieces.

● 负载-频次 Load-Frequency

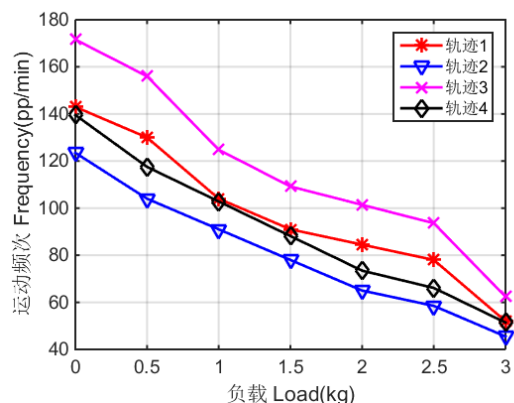

名称 Name	循环模式 Model	运动距离 Distance
轨迹1 Trajectory1	P1 → P2 → P3 → P4 → P3 → P2 → P1	h=25, b=305
轨迹2 Trajectory2	P1 → P2 → P3 → P4 → P3 → P2 → P1	h=25, b=500
轨迹3 Trajectory3	P1 → P2 → P3 → P2 → P1	h=25, b=305
轨迹4 Trajectory4	P1 → P2 → P3 → P2 → P1	h=25, b=500

特别注意：图中节拍时间在实际条件下测得，并且未包含俯仰运动，根据实际运用情况的不同（工具数据、路径半径、夹具启动等），节拍时间也会发生变化。

外形尺寸及运动范围
Outline dimensions and Working range (mm)

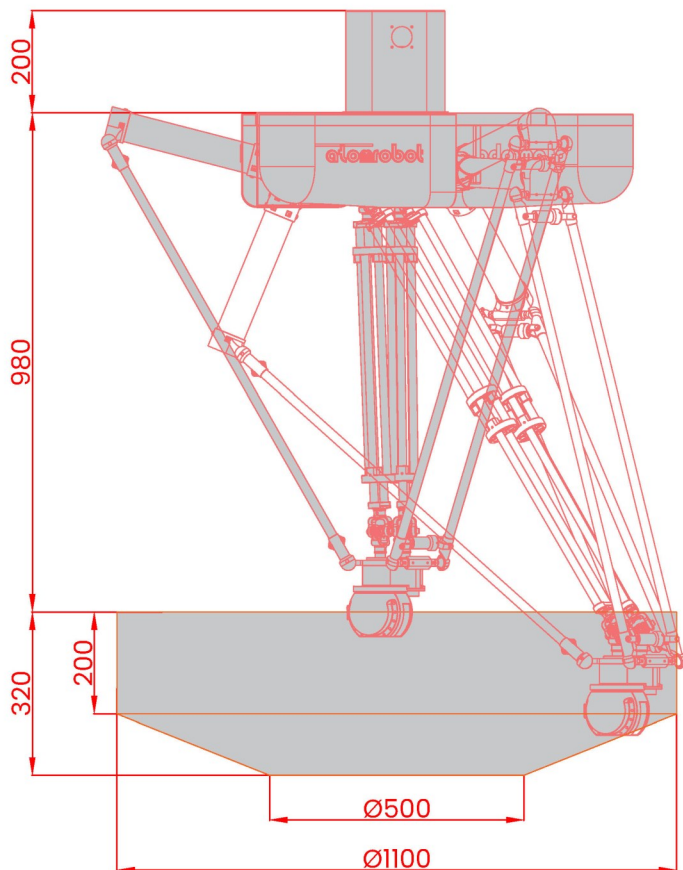

说明:
图示下部灰色工作空间代表末端俯仰转轴的中心点所能到达的区域。

Instruction:
The bottom gray workspace in the figure represents the area that can be reached by the center point of the end pitch axis.

法兰 Flange (mm)

基座安装 Base installation (mm)

